

**Herzlich Willkommen
beim
Hamburger
Gründer:innentag 2024**





HAMBURGER GRÜNDER:INNENTAG

Von der Idee zum fertigen Produkt

(Produktdesign/Produktentwicklung)

Beruflicher Hintergrund



Tim Förster

Dipl. Produkt-Designer

geb. 15.07.1969

- Selbstständig seit 2001
- Gründung formel23 DESIGNSTUDIO im Jahr 2002 mit **Christian Altmann**

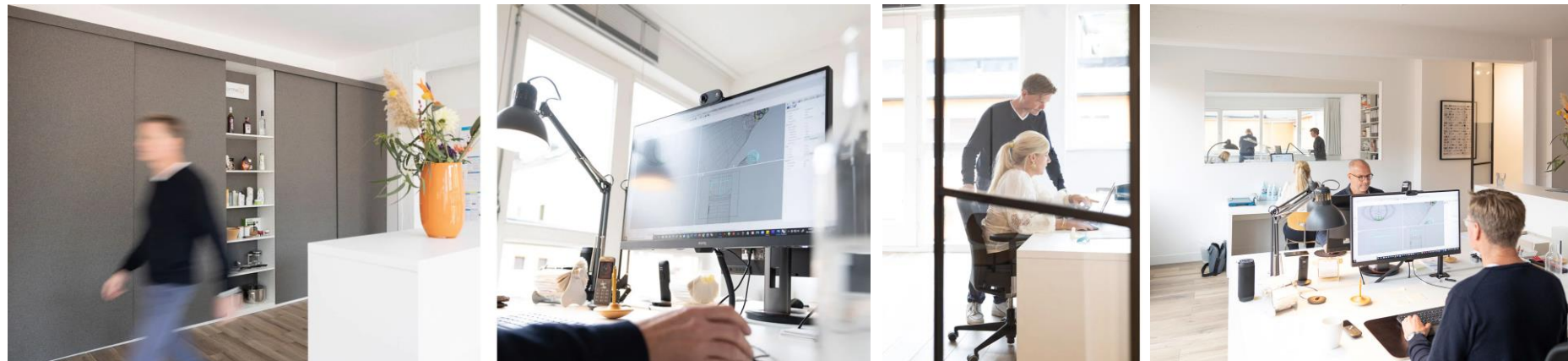

Tätigkeitsfelder/Kunden

TCHIBO

3D-Designentwicklung von zahlreichen non-food Produkten für unterschiedliche Bereiche wie: Küche, Bad, gedeckter Tisch, Wohnen, Kinderspielzeug, Konsumer-Elektronik. (15 jährige Zusammenarbeit)

REWE

Aufbau der Handelsmarke VIVESS mit zahlreichen 3D-non-food Produkten für unterschiedliche Bereiche wie: Küche, Bad, gedeckter Tisch, Wohnen, Konsumer-Elektronik. (4 jährige Zusammenarbeit)

dm

3D-Verpackungsentwicklungen für unterschiedliche Kosmetikprodukte (bestehende Zusammenarbeit)

FACKELMANN / CHEFKOCH / TASTY

Designentwicklung von unterschiedlichen Küchen- und Kochprodukten (bestehende Zusammenarbeit)

weitere Kunden

X-TAL Concepts (Laborgeräte)

flexi (Roll-Leine für Hunde)

KÜHNE (Glasflaschen-Entwicklungen)

HIPP (3D Verpackungsdesign)

BURDA (Nähutensilien)

Berendsohn AG (exklusive Werbemittel)

+ ca. 20 weitere Kunden

+ Projektbegleitungen als Produkt-Design-Experte bei Hamburger Agenturen

+ Beratung und Begleitung von Startups bzgl. Produkt-Design und Produktion

formel23
DESIGNSTUDIO

produkt
grafik & web
verpackung
design
agentur
leistungen
kontakt



These

**Wir behaupten, das fast
jeder in Deutschland ein
Produkt von uns verwendet!**

Unterschiedlichste Produkte, das macht
den Beruf so spannend!

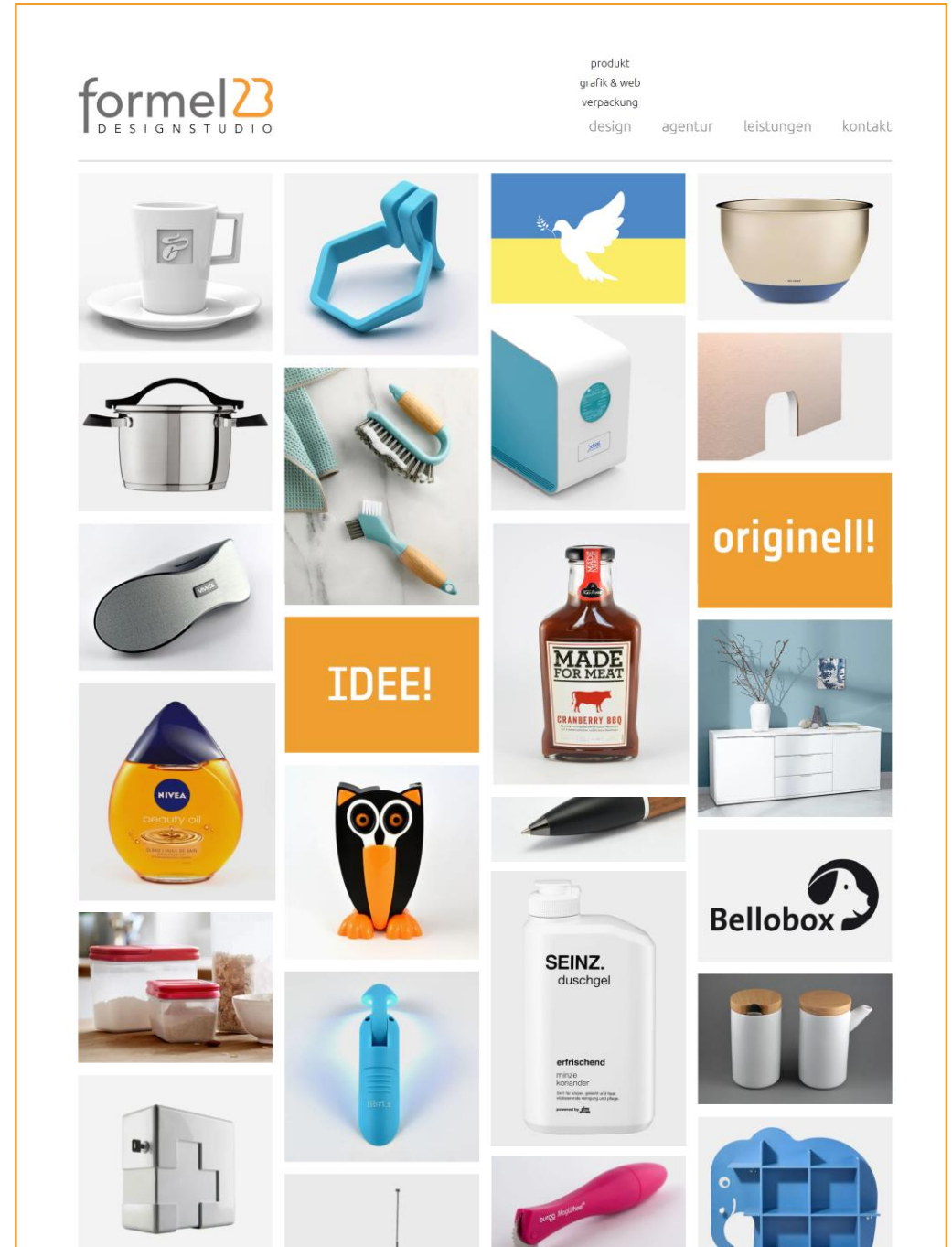

Worum geht heute?



**Es braucht nur
eine gute Idee!**



Ein Beispiel

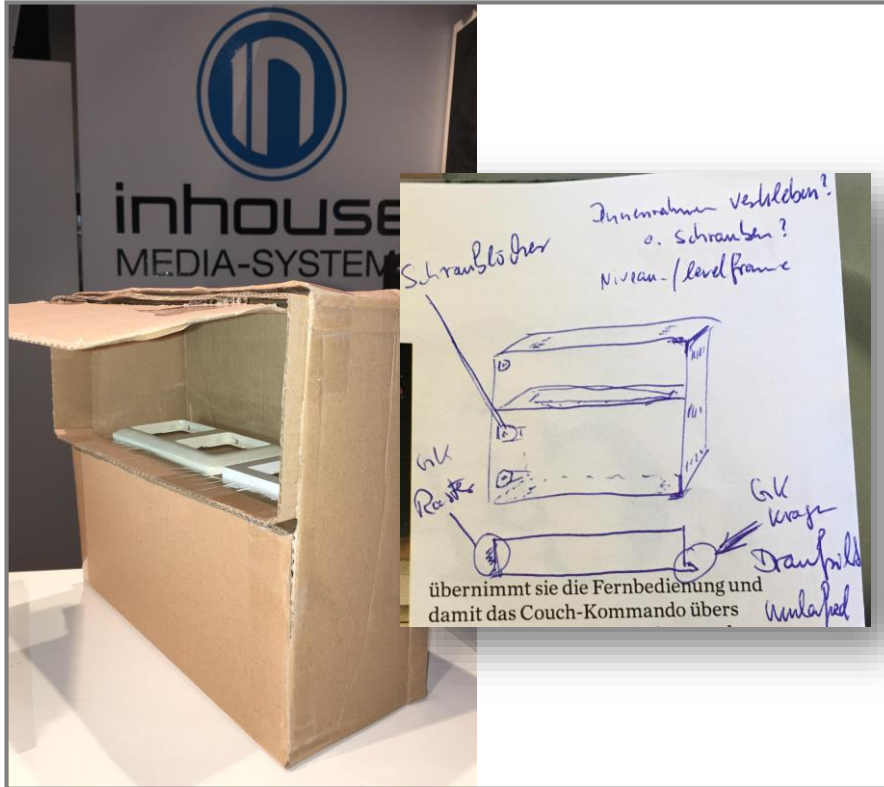

INBOX light

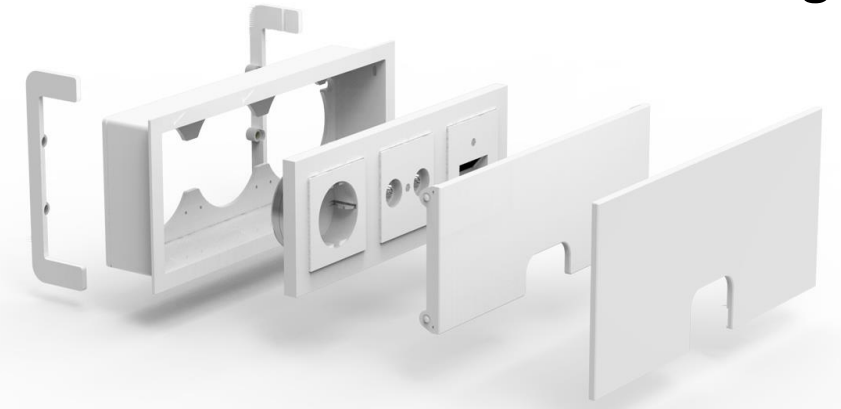

INBOX PLUS

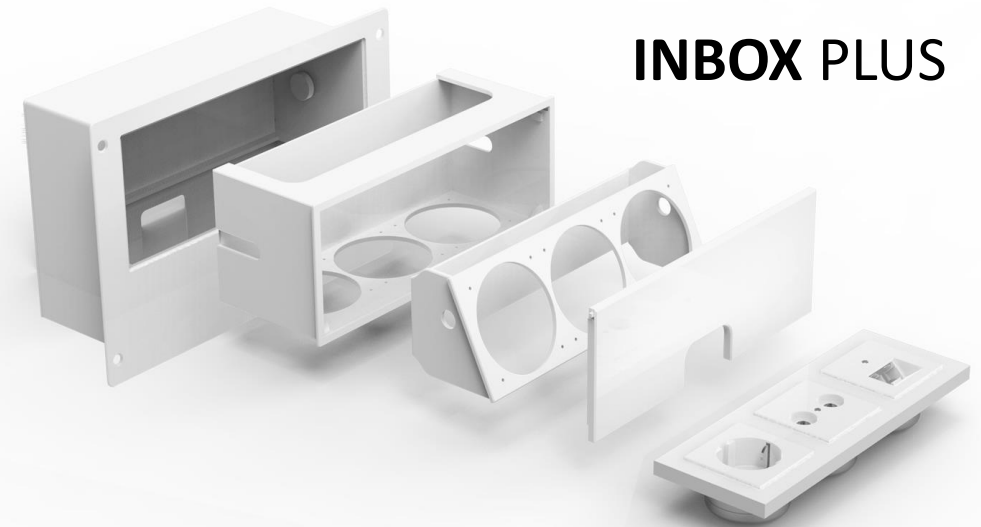

INBOX
Die unsichtbare Steckdose

INBOX

Die unsichtbare Steckdose

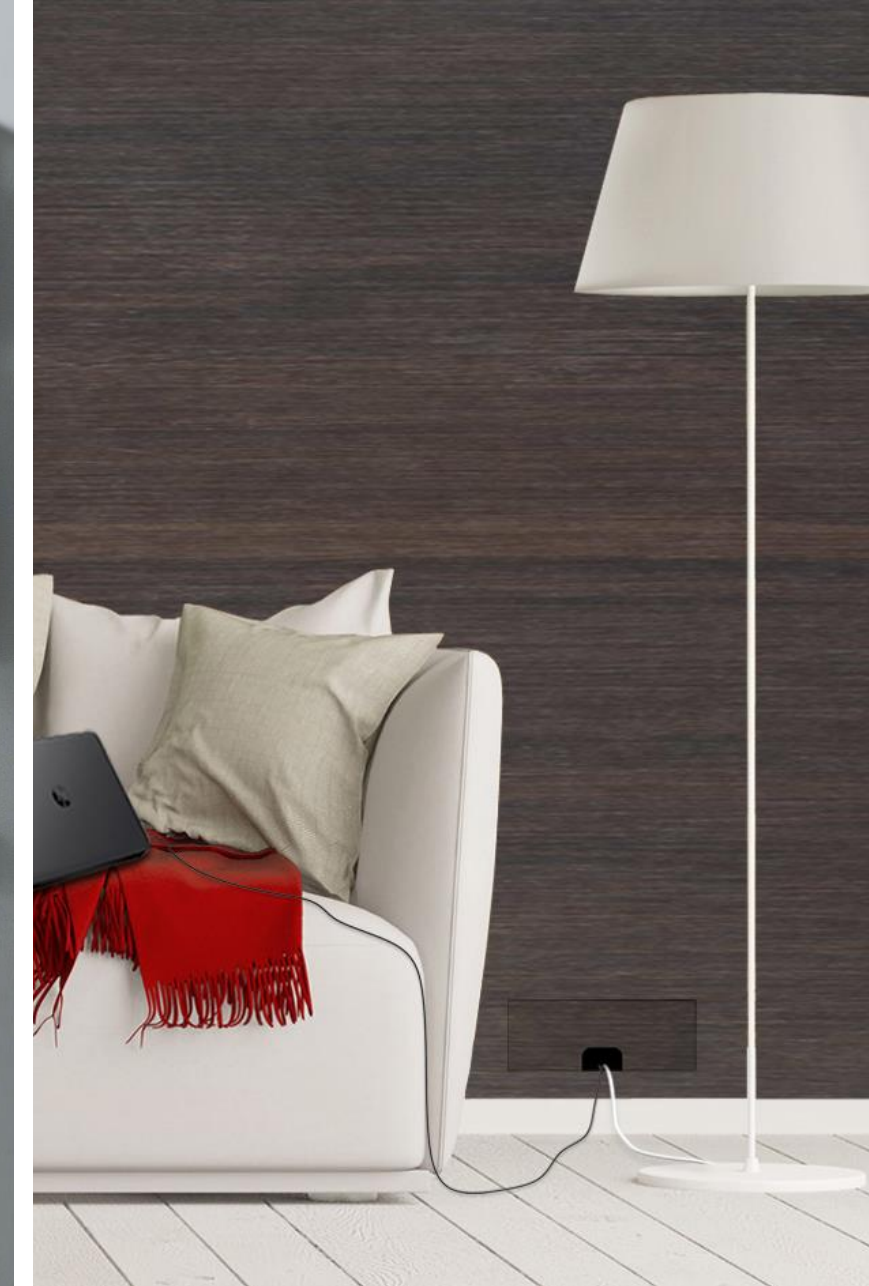

**Eine Idee,
viele Design-Lösungen**
oder der Blick in den Kochtopf!



Entwurfsprozess am Beispiel eines Kochlöffelhalters





BEISPIEL

Sie beauftragen Produktdesigner
mit der Entwicklung Ihrer Idee



Briefing

Zielgruppe, Material, Kostenrahmen, Formsprache...

1. Frage

Gibt's das schon?



Recherche

Rückschlüsse bei einer Recherche

- Der Markt / Anzahl an Varianten
- Unterschiede bei den Schutzrechten
- Deutsches Patentamt / Recherche

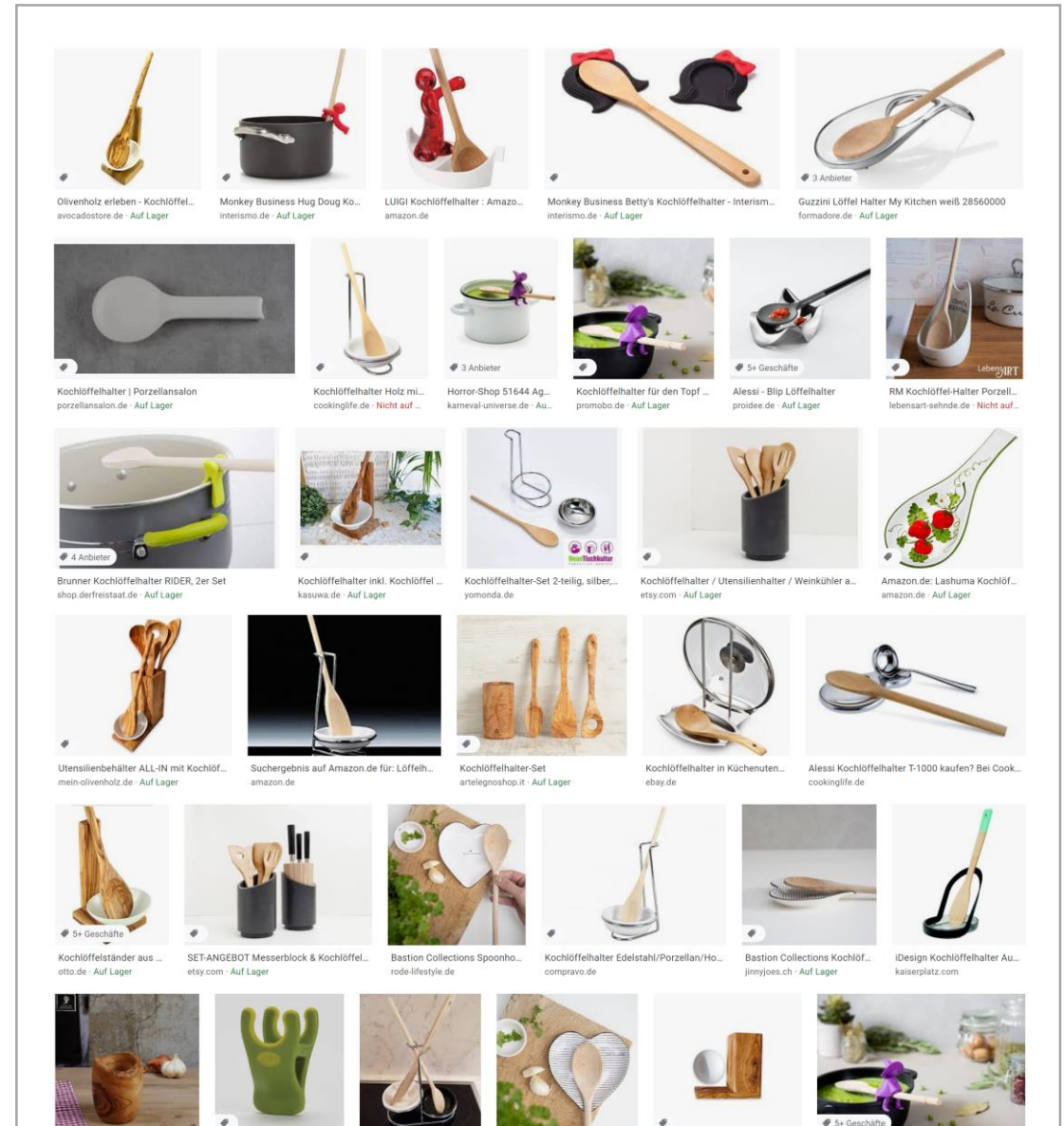

Handskizzen

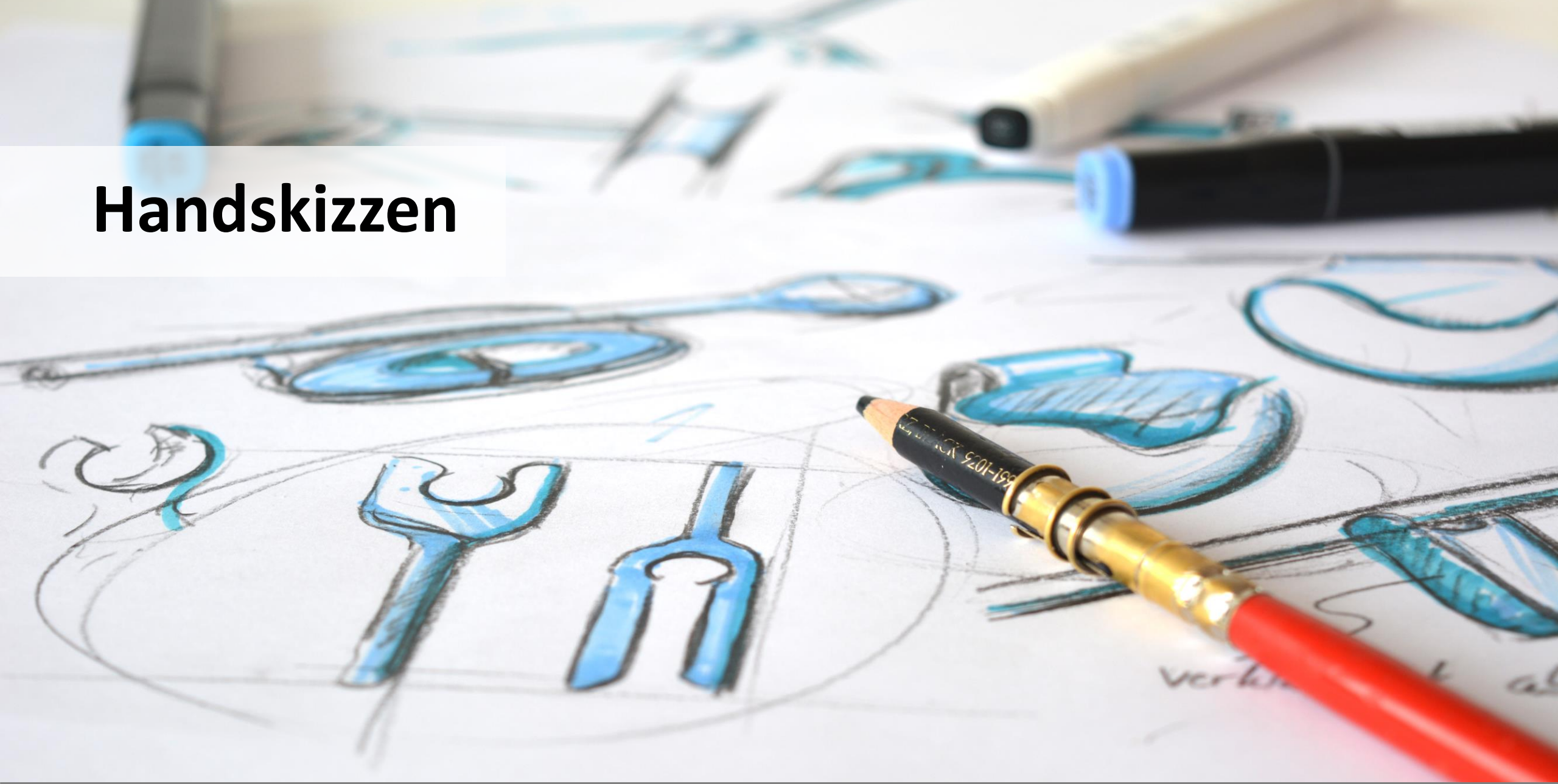

3D-CAD Konstruktion

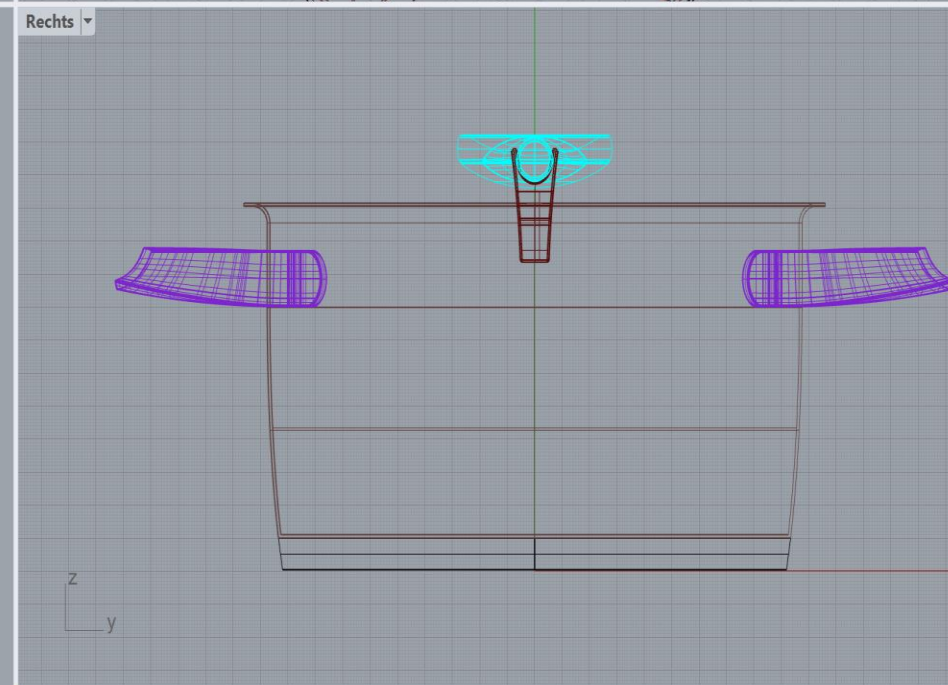
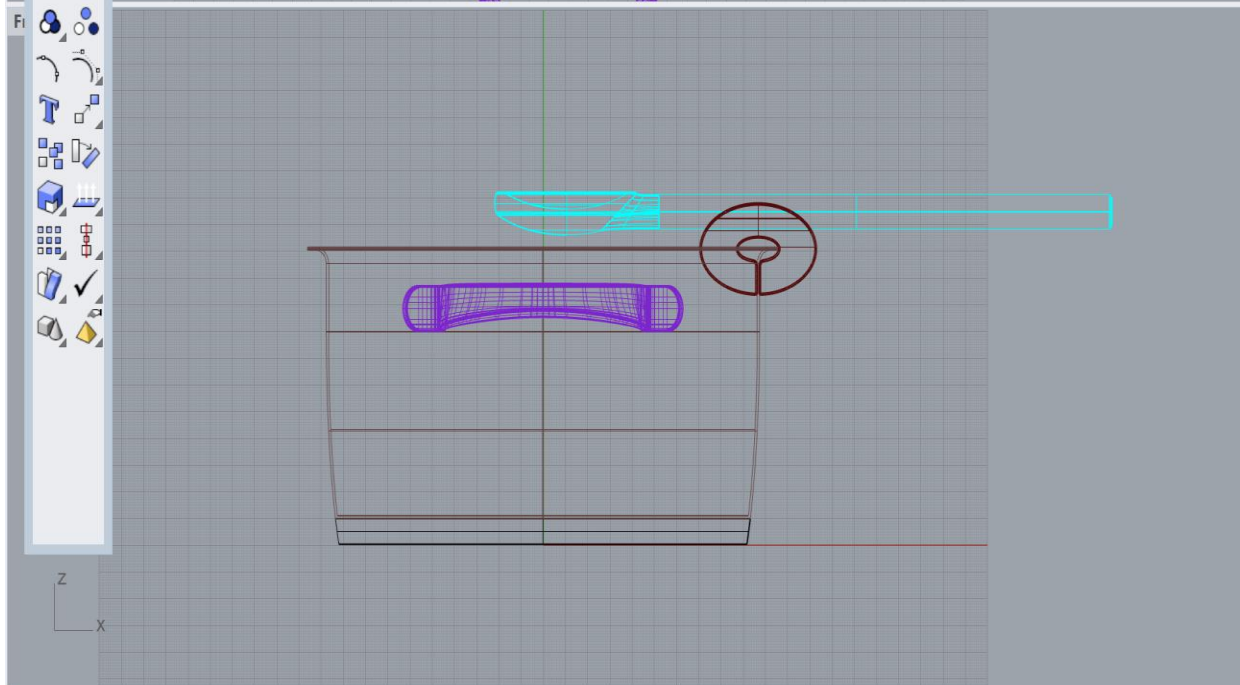
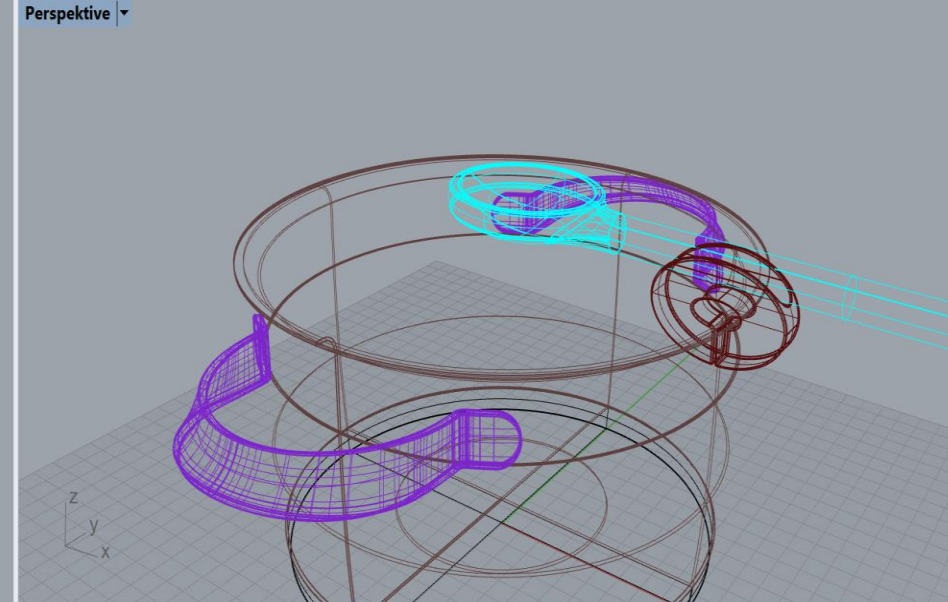
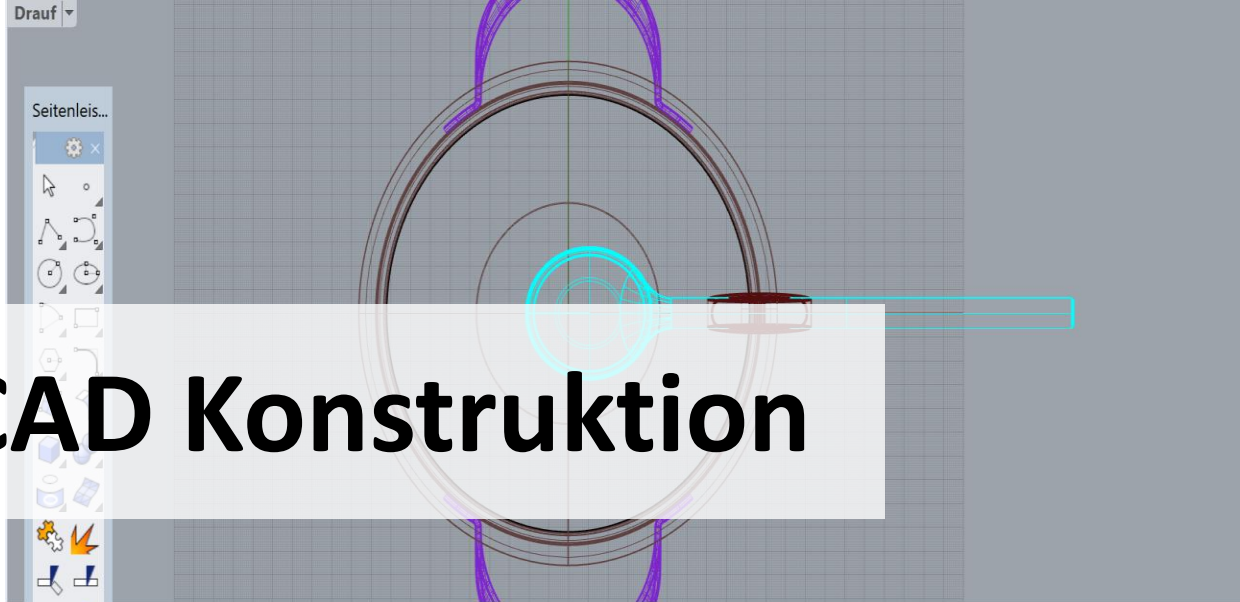

Entwurfs-Visualisierung

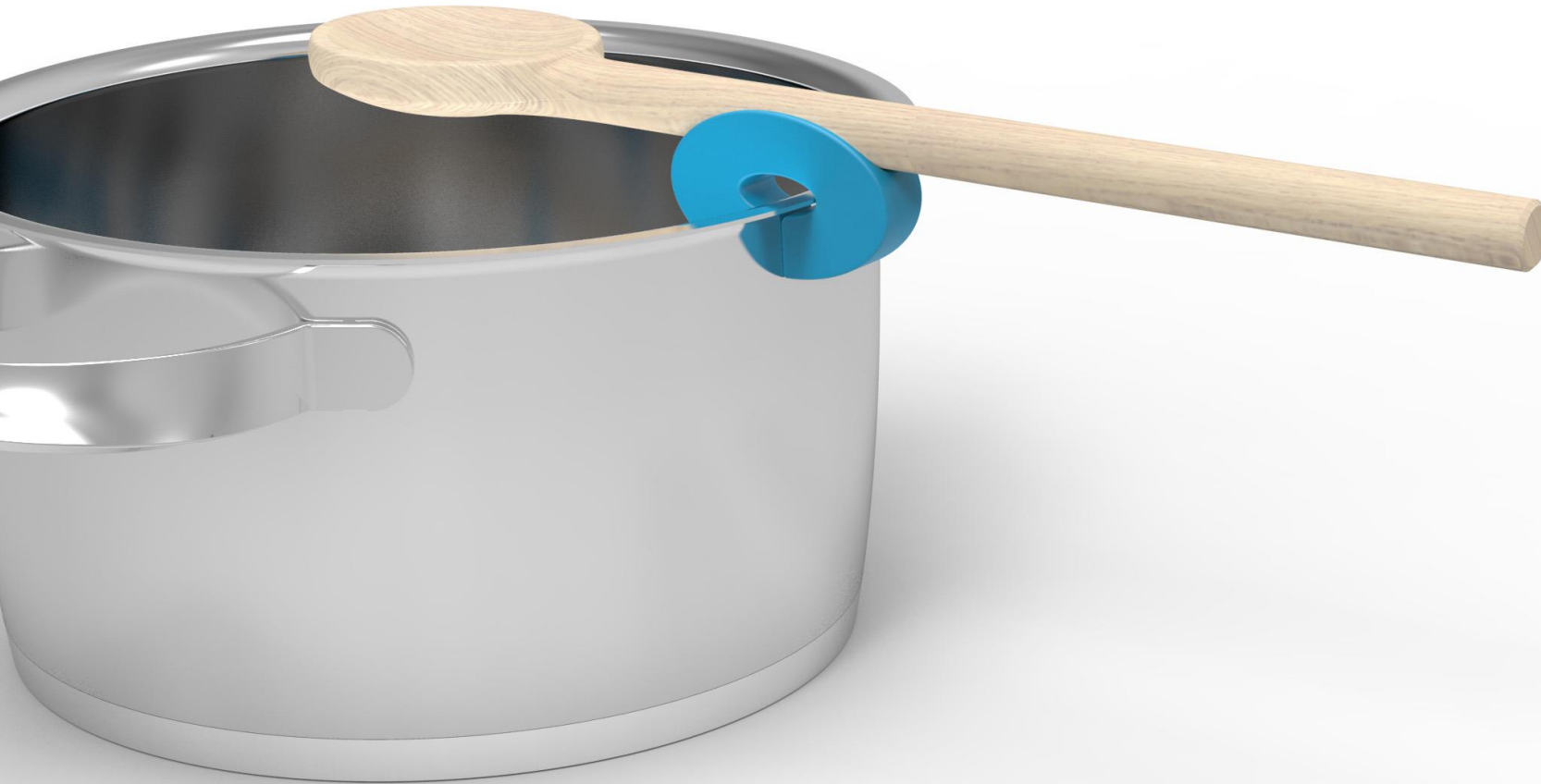

DESIGN #1

Entwurfs-Visualisierung

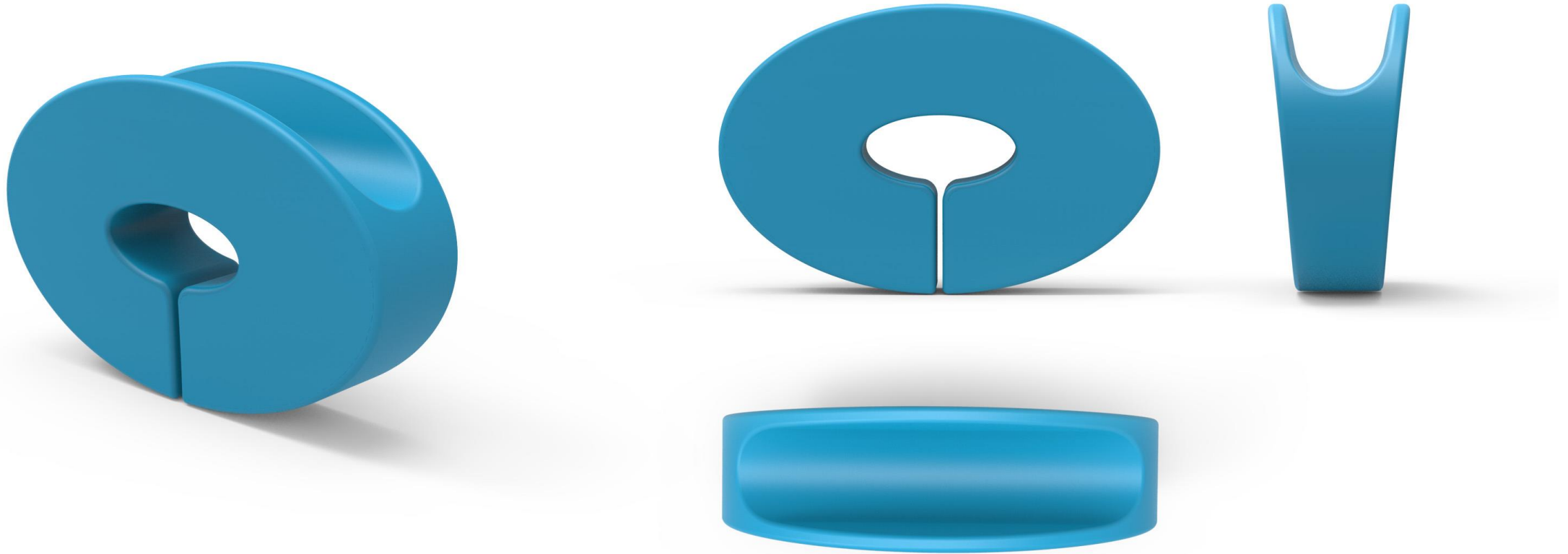

Entwurfs-Visualisierung



DESIGN #2

Entwurfs-Visualisierung

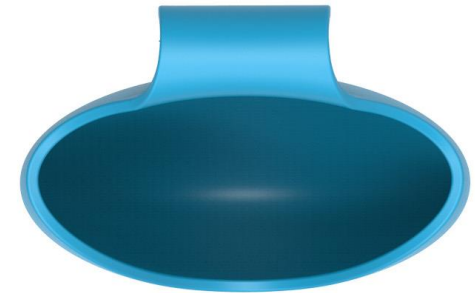
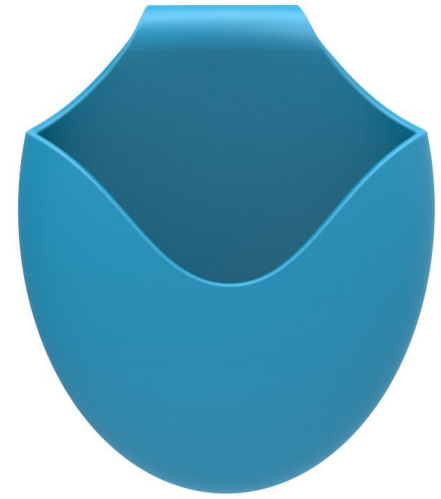

Entwurfs-Visualisierung



DESIGN #3

Entwurfs-Visualisierung



Entwurfs-Visualisierung



DESIGN #4

Entwurfs-Visualisierung

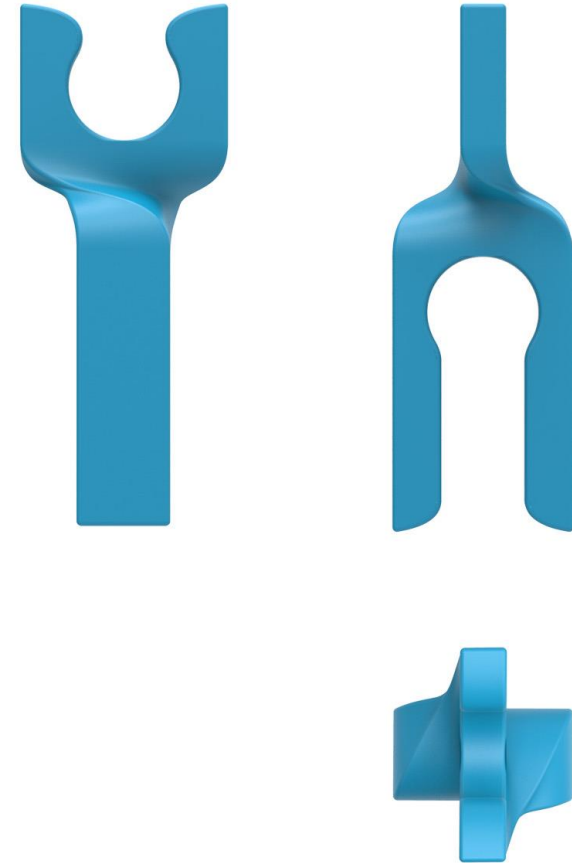
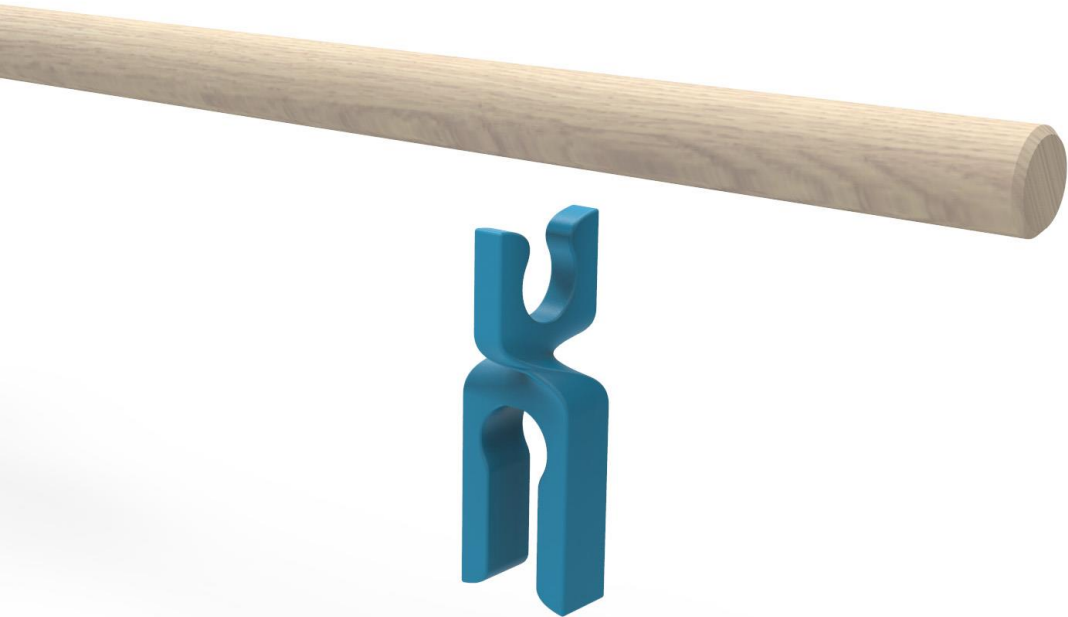

Entwurfs-Visualisierung



DESIGN #5

Entwurfs-Visualisierung

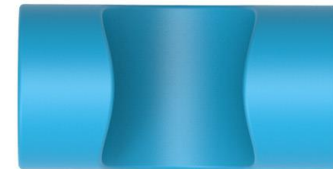
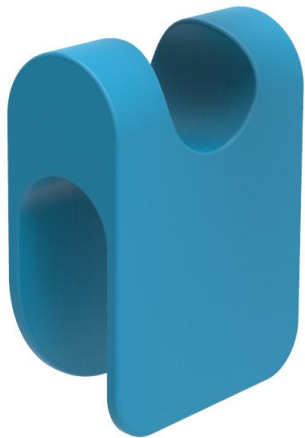

Entwurfs Visualisierung



DESIGN #6



Entwurfs-Visualisierung

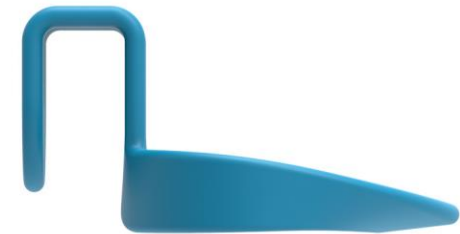
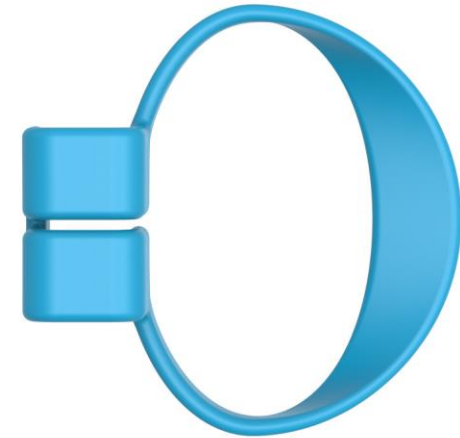
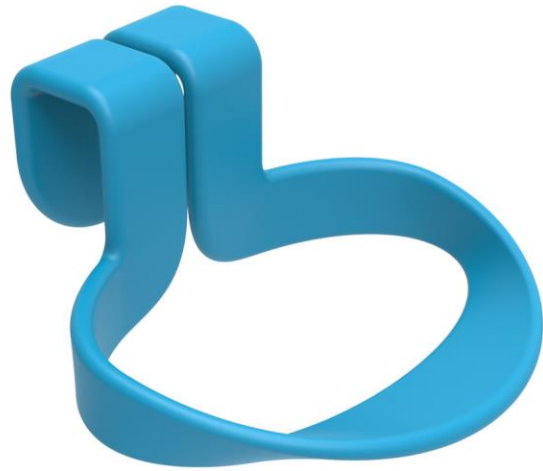

Entwurfs-Visualisierung



DESIGN #7

Entwurfs-Visualisierung

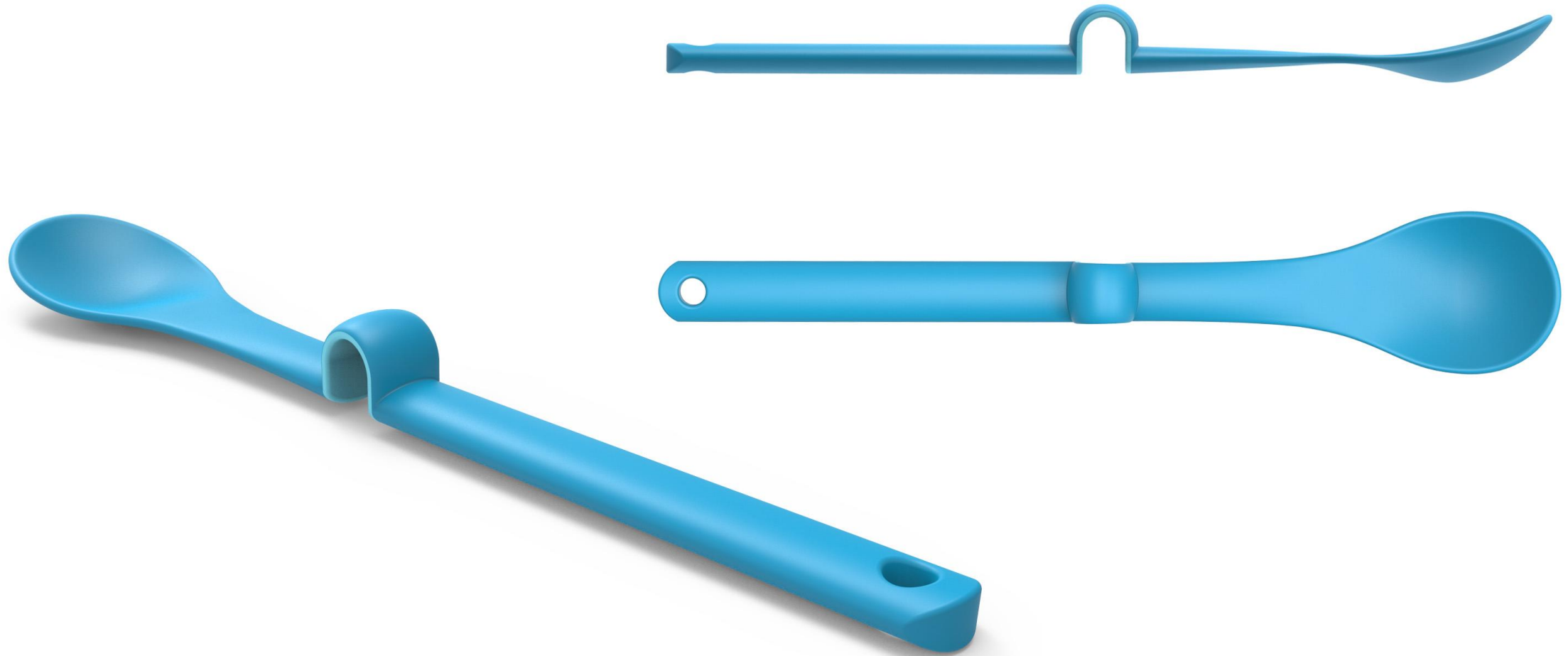

Präsentation



1



2



3

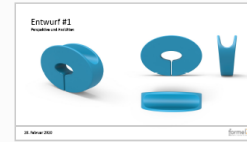

4



5



6

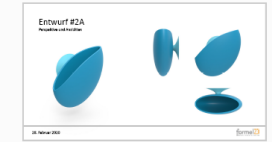

7



8



9

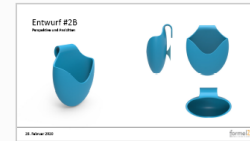

10



11



12



13



14



15

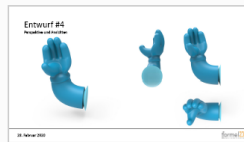

16



17



18

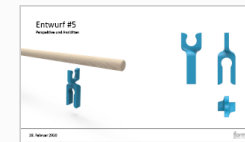

19



20

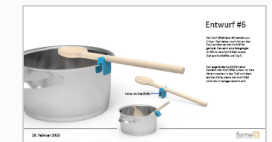

21

Korrekturphase



Entwurfsüberarbeitung

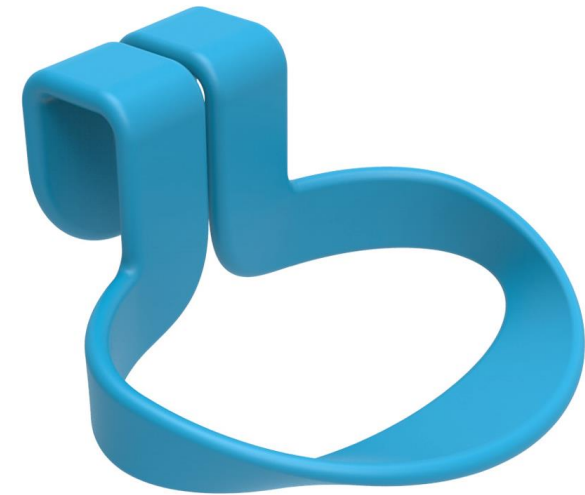

DESIGN #6

Entwurfsüberarbeitung

Moodboard - eckige, facettierte Form



Entwurfsüberarbeitung

eckige, facettierte Form

DESIGN #6

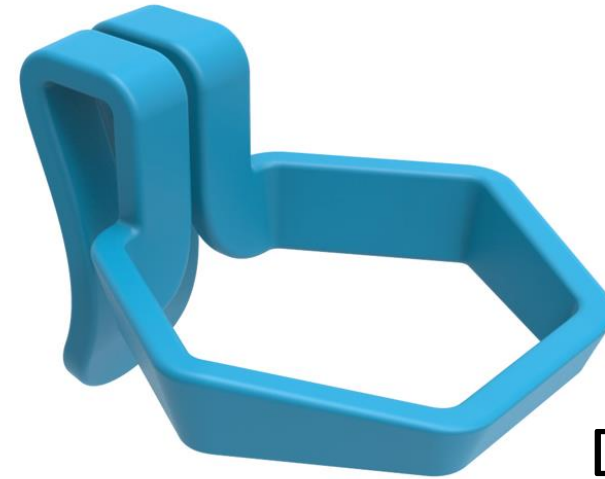
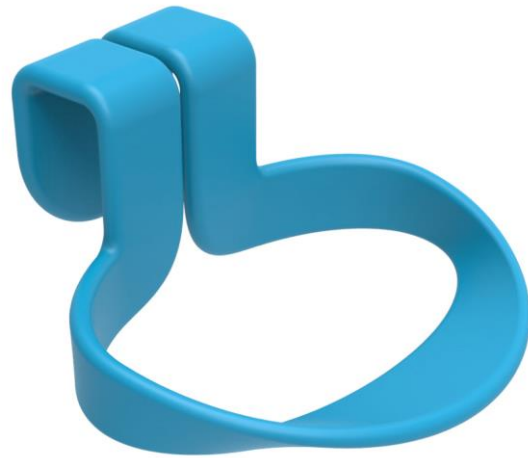

DESIGN #6B

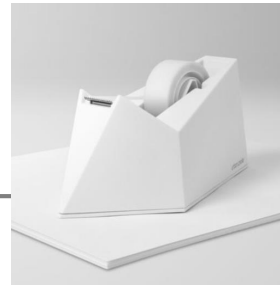

Entwurfs-Visualisierung

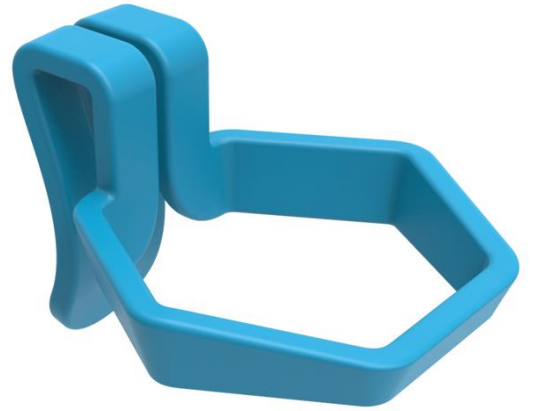

Entwurfs-Visualisierung

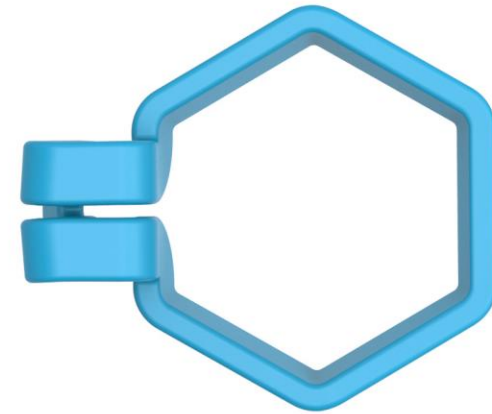
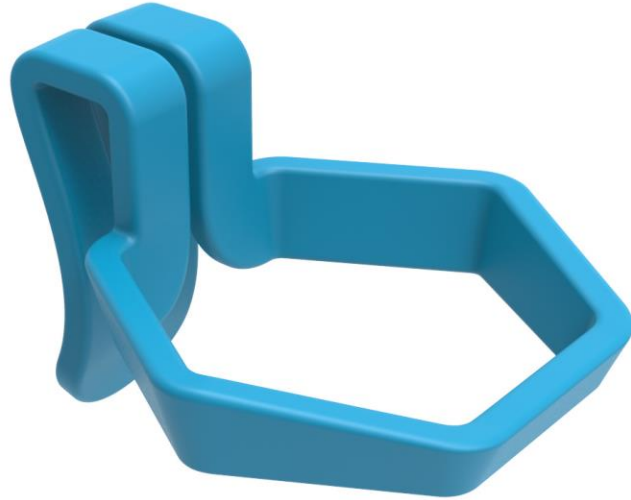

DESIGN #6B

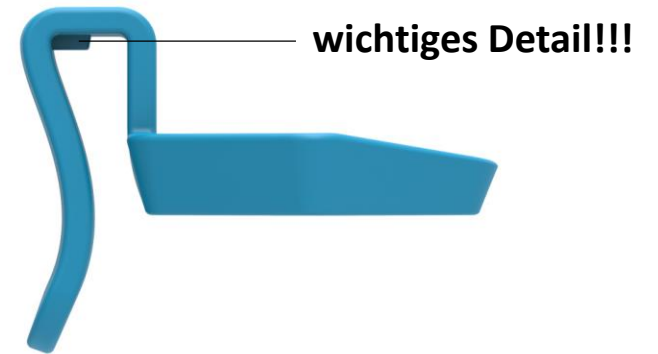
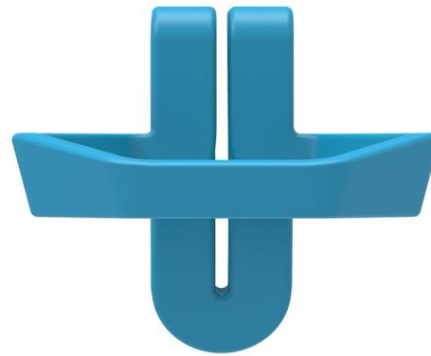



Mustererstellung

Modellbau / 3D-Druck

Mustererstellung / Funktionsversuche

Ein guter Produkt-Designer ist auch immer ein Erfinder



Anfrageunterlagen

Visualisierungen, technische Zeichnungen, 3D-Daten

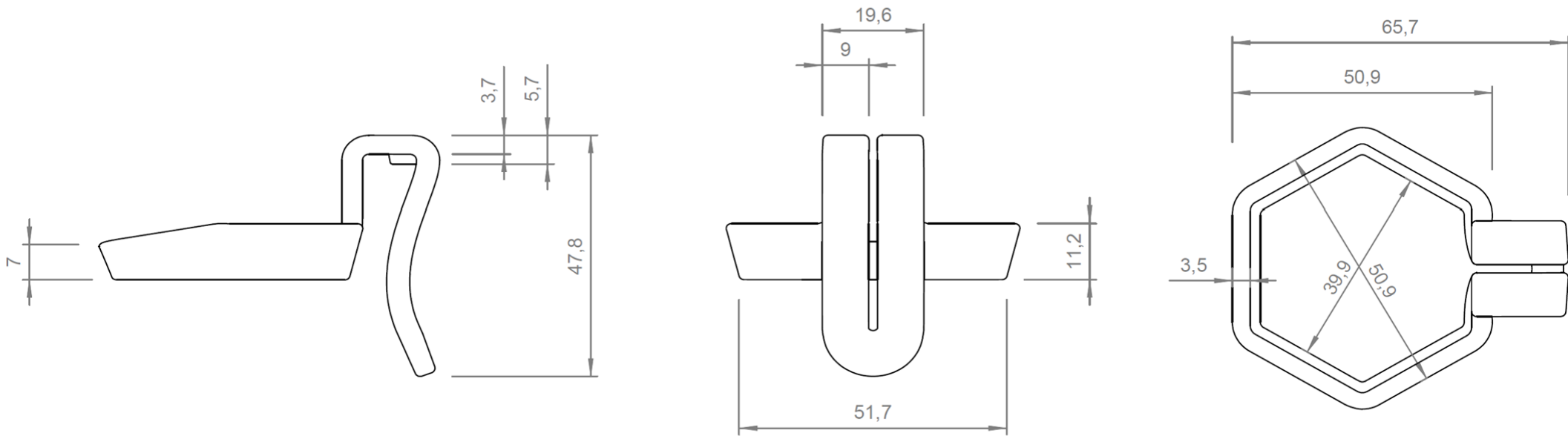



Logo Verpackung Website



Themen rund um die Produktentwicklung



Designberufe

Produkt-Designer/Industrie-Designer

Grafik-Designer, 2D-Grafik-Verpackungsdesigner, Webdesigner, CI-Designer

Textil-Designer

Automobil-Designer

Interior-Designer/Innenarchitekt

Möbel Designer

dm-drogerie markt GmbH + Co. KG
Carl-Metz-Str. 1
76185 Karlsruhe

Kostenbeispiele

Angebot über die Designentwicklung einer Flasche

Aufgabe:

Für babylove soll eine neue Flaschenranne
folgenden Flaschengrößen: 50ml, 250ml
Die neue Flaschenform soll ein moder-
Handhabung sollte erwachsenen-

1. Entwurf der Flaschenform

In der ersten Phase entwi-
Briefing widerspiegeln u-
wir die bestehenden V-

Von den Entwürfen
ativen.

Materialien

Materialeigenschaften
Materialkombinationen
Nachhaltigkeit

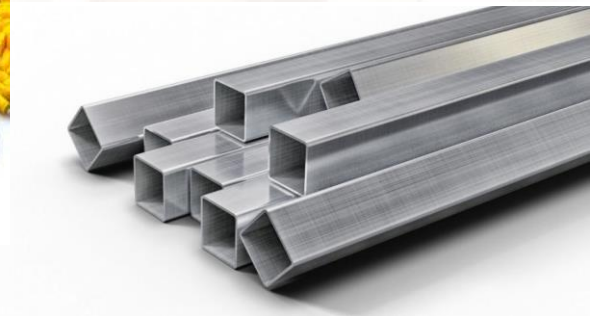
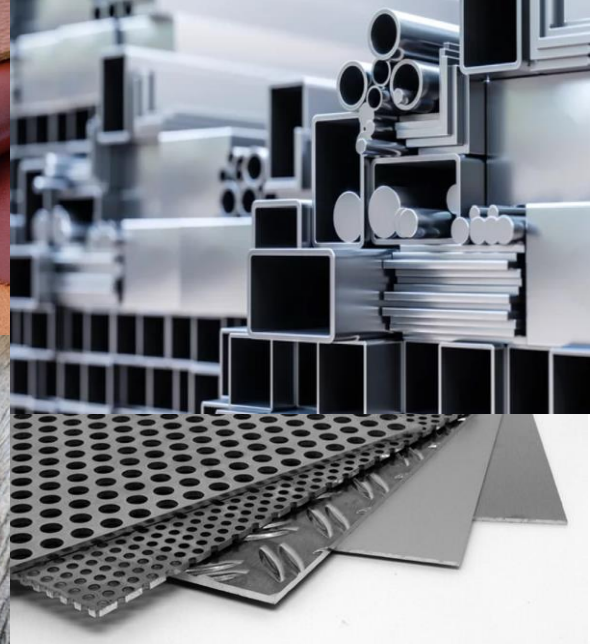

Herstellungstechniken

Kunststoffverarbeitung

Spritzgießen, Streckblasen, Plattenmaterial...

Metallverarbeitung

Metall-Druckguss, Tiefziehen...

Glasverarbeitung

Pressglas, Glasblasen...

Holzverarbeitung

Formholz, Plattenmaterial...

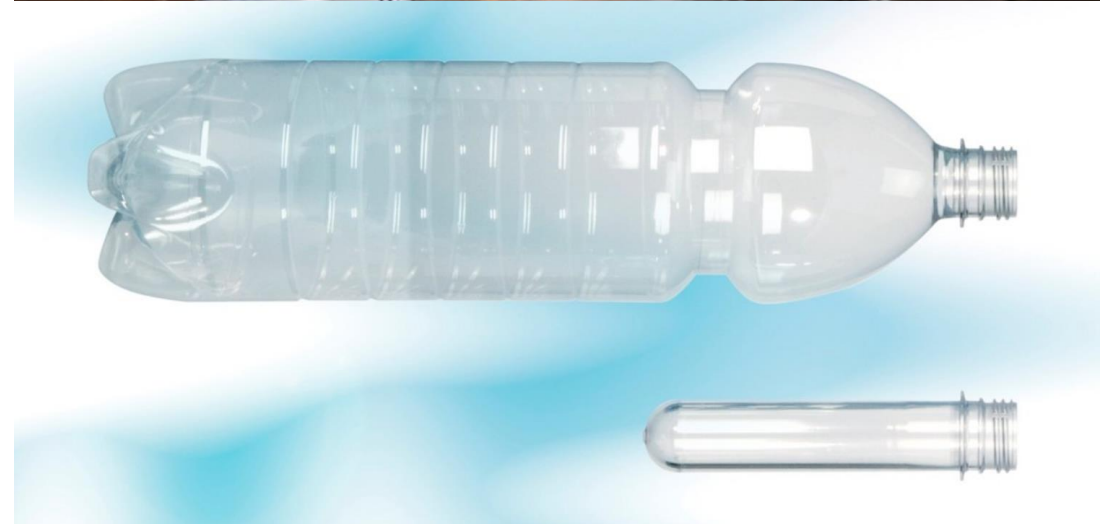

Farbsysteme



Künstliche Intelligenz

DATA MINING



PROBLEM SOLVING

AUTOMATION



MACHINE LEARNING

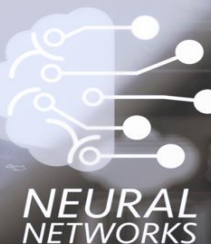

Finanzierungsmöglichkeiten

Crowdfunding (was brauche ich)

Investor (Präsentation Ihrer Idee)

Vertriebspartner (Vorstellung Ihrer Idee)

Höhle der Löwen 😊



Schutzrechte

Patente, Gebrauchsmuster,
Designschutz, Markenrechte

NDA - Geheimhaltungserklärung

The screenshot shows the homepage of the DPMA (Deutsches Patent- und Markenamt). The browser address bar displays 'dpma.de/index.html'. The website header includes the DPMA logo, the text 'Deutsches Patent- und Markenamt', and navigation links for 'ENGLISH', 'KONTAKT', 'SITEMAP', 'GEBÄRDENSPRACHE', and 'LEICHTE SPRACHE'. A search bar with the placeholder 'Suchbegriff' is located in the top right. Below the header, a navigation menu lists 'Das DPMA', 'Patente', 'Gebrauchsmuster', 'Marken', 'Designs', 'Recherche', and 'Service'. The main content area features a large image of the Munich Olympic Stadium with three promotional banners: 'PIZNET-AKTIONSWOCHEN IM SEPTEMBER' with the sub-heading 'Orientierungsberatungen für kleine und mittlere Unternehmen', '50 JAHRE OLYMPISCHE SPIELE IN MÜNCHEN' with the sub-heading 'Die "heiteren Spiele" und die Schutzrechte', and 'ZAHL DES MONATS' with the sub-heading 'Beim DPMA seit 1877 angemeldete Patente'. Below the banners, there are three service boxes: 'DPMAregister' (Publications and Register for Patents, Utility Models, Trademarks and Designs), 'DEPATISnet' (Electronic Patent Document Archive), and 'DPMAdirektPro und DPMAdirektWeb' (Electronically filing rights). At the bottom, an 'Aktuelles' section lists two job openings: one dated 29.08.22 for a medical professional and another dated 22.08.22 for a social media editor in Munich.

Mögliche Hersteller

Wo produzieren lassen (Ausland/Inland)?
Wie finde ich einen Hersteller?



Eigener Vertrieb

Website/Shops/Instagram/Amazon

Fremdvertrieb

Ideenverkauf/Lizenzen/Kombination



Seminarraum hei. Seminar



Für wen ist das Seminar interessant?

Für jeden, der eine Produktidee hat!

Egal ob sie nur als einfache Skizze existiert oder nur noch verfeinert werden muß

Was nehmen Sie aus dem Seminar mit?

- Ansätze, Hinweise und Beispiele, wie Sie Ihre Produktidee umsetzen können
- Grundwissen über die industrielle Produktion von Produkten
- Individuelle Betrachtung und Beurteilung Ihrer Idee (auf Wunsch)
- Eventuelle Vermittlung von Kontakten zu (Produzenten/Designern/Vertriebsfirmen)



Beispiel Bellobox





Vielen Dank für Ihre Teilnahme und Aufmerksamkeit!

Tim Förster

www.formel23.de

Telefon: (040) 399 077 27

email: info@formel23.de

hei. Hamburger Existenzgründungsinitiative

www.hei.hamburg

Telefon: (040) 611 700 700

email: info@hei.hamburg

**Herzlich Willkommen
beim
Hamburger
Gründer:innentag 2024**

